

IBUTTON R/W M PROXIMITY READER

MIFARE PROXIMITY READER WITH READ/WRITE CAPABILITY

REF: 14046000



(IN 60839-11-1) CLASE III, SECURITY GRADE 4

▶ IBUTTON R/W M PROXIMITY READER



MIFARE® ISO14443A (13,56 MHz) card proximity reader with read/write capability. This reader allows the CSN (Chip Serial Number) of the card to be read, as well as read/write operations of data in the card memory. Access to this data can be gained through a cryptographic password for a securer data processing. This reader is especially appropriate for installations with the DOC system (Dorlet On Card). It can be used both as stand-alone access point and as

on-line synchronism point.

Its small size makes it ideal for placing directly on metal profiles. Can be installed directly on door with "reader+handle" type of configuration.

CHARACTERISTICS

- Made with high-resistance polycarbonate plastic with stainless steel base.
- Metallic finish and LEDs to check the status:red, green and beep.
- The proximity technology available is MIFARE® ISO14443A (13,56 MHz) with read and write capacity on card.
- It also allows the CSN of MIFARE® ULTRALIGHT, MIFARE® DESFIRE®, MIFARE® DESFIRE® EV1 cards to be read.
- Recommended for both access control instalations with centralised operation and with DOC operation (Dorlet On Card).
- Surface mounted, a bracket can be purchased for assembly on pipe or conduit, including tamper signal over reader communication.
- Conectable to any Dorlet access control CPU of the AS, ASD and AHS series.

▶ TECHNICAL SPECIFICATIONS

Dimensions:	80 x 29 x 20 mm.
Material:	Polycarbonate plastic
Finish:	Black
Reading technology:	Proximity MIFARE®
Reading frequency:	13,56 MHz.
Reading range (R/W):	Up to 5 cm. (3 cm.)
Writting possibility:	Yes
Power supply:	12 VDC.
Maximum consumption:	125 mA.
Operating range:	from -10°C to 55°C (up to 93% humidity)
Signaling:	Red-green led and buzzer
Protection:	IP55, IK04
Connections:	4 wires (consult tipe of wire in manual)
Certification:	(in 60839-11-1) clase iii, security grade 4

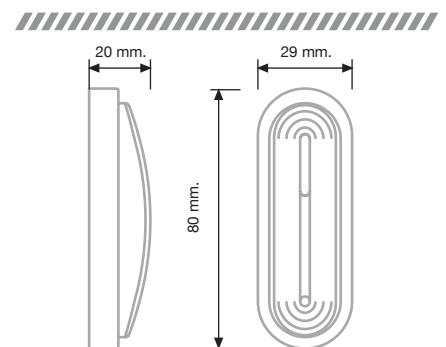

This document contained in this document is subject to change without prior warning. Nothing in this document can be interpreted as an additional warranty. Dorlet S.A.U does not accept responsibility for any errors or technical or editorial omission contained in this document.